

Note:<注意>

Mechanical:<机械性能>

.Contact force: 40g±20g at 0.60mm working stroke
<接触弹力: 40g±20g在0.60mm的工作行程>
.Life test: 20,000 cycles
<寿命: 20000次>

Electrical:<电气性能>

.Rated current & voltage: DC 12V, 1A
<额定电压, 电流: DC 12V, 1A>
.Contact resistance: 50 milliohm Max.
<接触阻抗: 50 milliohm Max.>
100% open & short test.
<100%导通,短路测试>

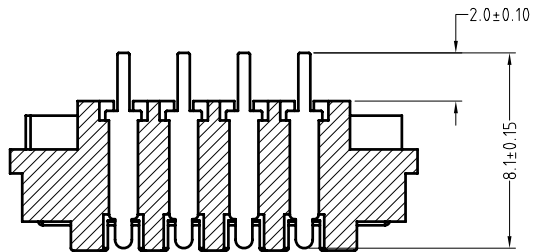

剖面 A-A

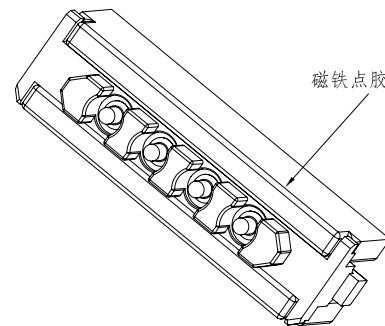

Approve Sign

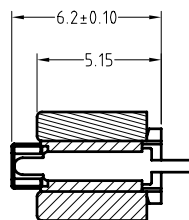
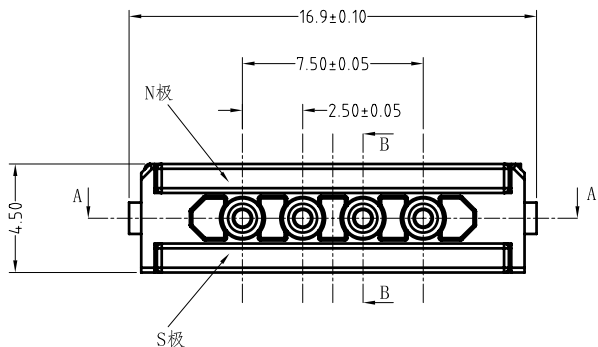
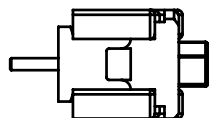

剖面 B-B

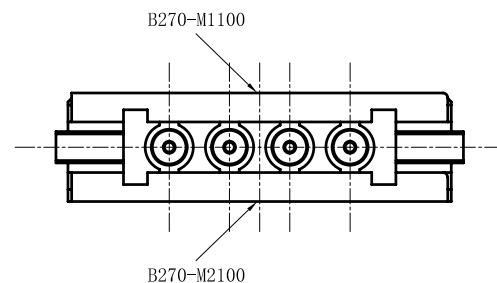

4	Black HTN UL94 V-0 <黑色 HTN UL94 V-0>	B270-H1111	1
3	Pogo pin plating 0.25um Au <弹簧针 电镀金0.25um>		4
2	N48 NdFeB Magnet plating Black Ni <N48 钕铁硼磁铁 表面镀黑镍>	N270-M2100	1
1	N48 NdFeB Magnet plating Black Ni <N48 钕铁硼磁铁 表面镀黑镍>	B270-M1100	1
序号 <NO.>	规格 <Specification>	料号 <P/N>	数量 <Qty>

SCALE	10:1	UNIT:mm	THIS DOCUMENT IS THE SOLE PROPERTY OF CFE CORPORATION CO.,LTD., AND SHOULD NOT BE USED IN WHOLE OR IN PART WITHOUT PRIOR WRITTEN PERMISSION.	东莞市川富电子有限公司 CFE CORPORATION CO.,LTD.	
ANGEL	±2°	A4			
0~6	±0.10		SHEET: 1 of 1	PART NO.	M-BP27031-04250H0C
6~30	±0.20	DRAW		FILE NAME	BP270XX
30~150	±0.30	CHECK		TITLE.	Pogo pin Connector
GENERAL TOLERANCE UNLESS OTHERWISE NOTED		APPRO			

ECN(DCN) NO.	REV	DATE	DESCRIPTION
	D0	2015.11.26	NEW