

Note:<注意>
 Mechanical:<机械性能>
 .Contact force: 70g±20g at 1.0mm working stroke
 <接触弹力: 70g±20g在1.0mm的工作行程>
 .Full stroke: 1.40mm
 <最大行程: 1.40mm>
 .Life test: 50,000 cycles
 <寿命: 50000次>

Electrical:<电气性能>
 .Rated current & voltage: DC 12V, 2A Max.
 <额定电压, 电流: DC 12V, 2A>
 .Contact resistance: 50 milliohm Max.
 <接触阻抗: 50 milliohm Max.>
 100% open & short test.
 <100%导通, 短路测试>

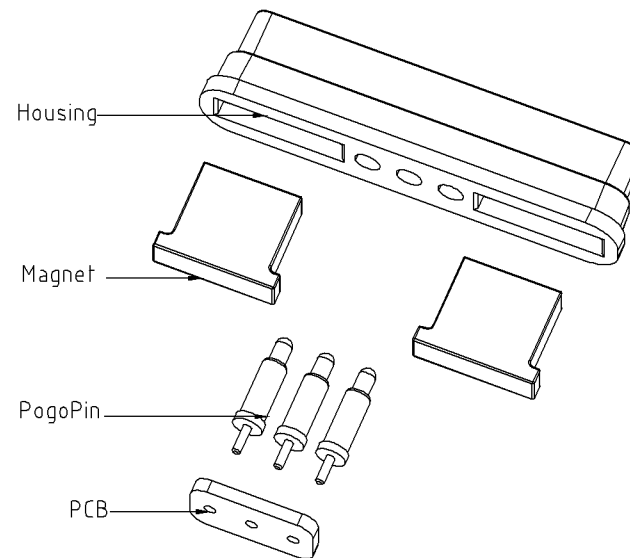
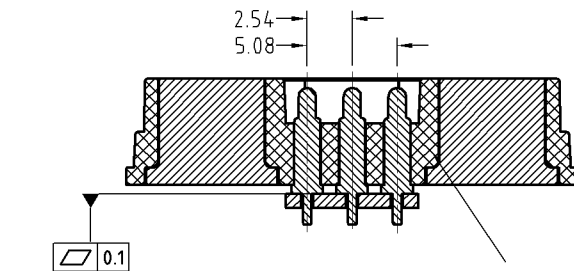
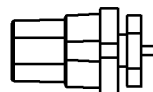
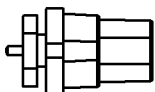
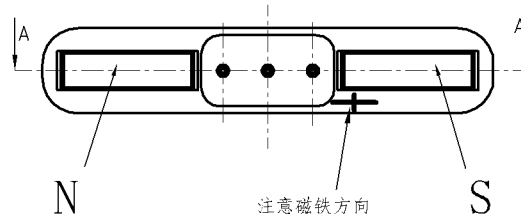
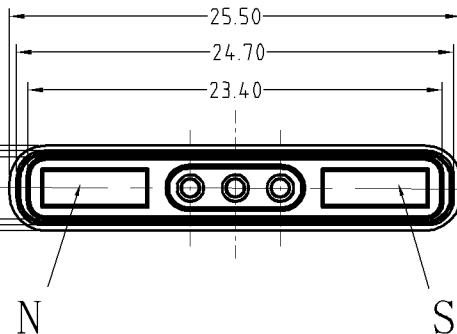
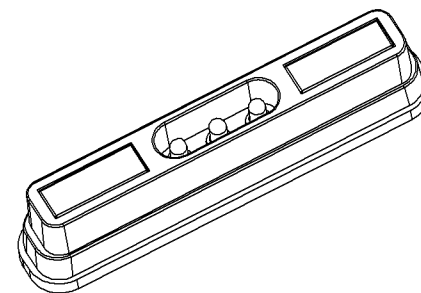
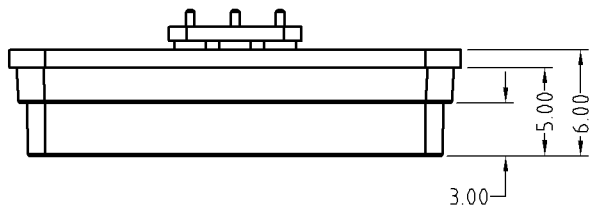

4	PCB Polyester fiber board <PCB 聚酯纤维板>	B701-F3103	1
4	Pogo pin plating 0.125um Au <弹簧针 电镀金0.125um>	MP210-2111	3
3	N52 NdFeB Magnet plating Ni-Cu-Ni <N52 钕铁硼磁铁 表面镀镍铜镍>	B647-M1101	1
2	N52 NdFeB Magnet plating Ni-Cu-Ni <N52 钕铁硼磁铁 表面镀镍铜镍>	B647-M2102	1
1	Black HTN UL94 V-0 <黑色 HTN UL94 V-0>	B701-H3003	1
序号 <NO.>	规格 <Specification>	料号 <P/N>	数量 <Qty>

SCALE	10:1	UNIT:mm	THIS DOCUMENT IS THE SOLE PROPERTY OF CFE CORPORATION CO.,LTD., AND SHOULD NOT BE USED IN WHOLE OR IN PART WITHOUT PRIOR WRITTEN PERMISSION.
ANGEL	±2°	A4	
0~6	±0.10		
6~30	±0.20	DRAW	
30~150	±0.30	CHECK	
GENERAL TOLERANCE UNLESS OTHERWISE NOTED		APPRO	

		东莞市川富电子有限公司 CFE CORPORATION CO.,LTD.	
SHEET: 1 of 1		PART NO.	M-BP70102-03254A0B
		FILE NAME	BP701XX
		TITLE.	Pogo pin Connector

ECN(DCN) NO.	REV	DATE	DESCRIPTION
	D0	2016.07.30	NEW