

Note:

Mechanical:

.Contact force: 70g±20g at 0.9mm working stroke

.Life test: 20,000 cycles

Electrical:

.Rated current & voltage: DC 12V; 2A

.Contact resistance: 50 milliohm Max.

100% open & short test.

To ensure the best usage, please operate it based on the working height.
Based on the engineering drawings, shall not exceed the maximum allowed compression.



Approve Sign

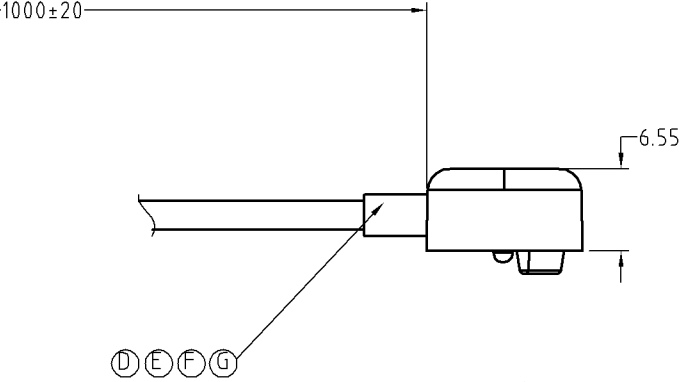
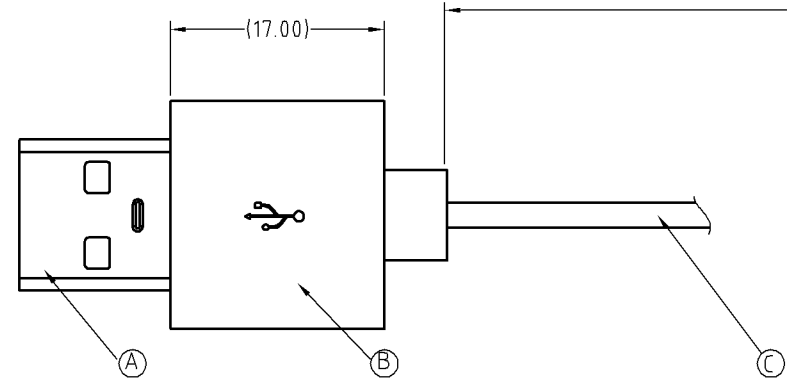
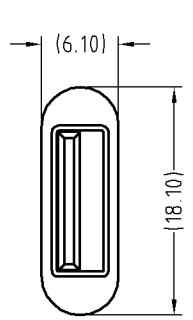

Pogo pin conn

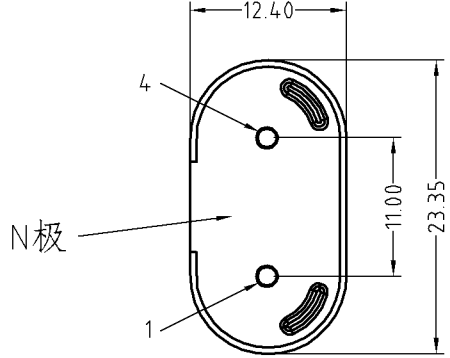

USB→Pogo pin conn
1_Vcc_1
4_GND_4

BOM		
序号	规格	数量
G	Pogo pin	2
F	磁铁 N38 表面镀镍	1
E	PCB	1
D	上下盖胶件 白色ABS	2
C	类似苹果线OD3.0, 2C, TPE材质, 带SR	1
B	白色 TPE RoHS	1
A	USB/AM公焊线式IU" ROHS 盐雾48小时	1

SCALE	10:1	UNIT:mm	THIS DOCUMENT IS THE SOLE PROPERTY OF CFE CORPORATION CO.,LTD., AND SHOULD NOT BE USED IN WHOLE OR IN PART WITHOUT PRIOR WRITTEN PERMISSION.	
ANGEL	±1°	A4		
0~6	±0.10			SHEET: 1 of 1
6~30	±0.15	DRAW		
30~150	±0.20	CHECK		
GENERAL TOLERANCE UNLESS OTHERWISE NOTED		APPRO		

		东莞市川富电子有限公司 CFE CORPORATION CO.,LTD.	
PART NO.	CM-BP41511-02110H0C	FILE NAME	BP415XX
TITLE.	Pogo pin connector		

ECN(DCN) NO.	D0	2015.19	NEW
REV	DATE	DESCRIPTION	