

Note:<注意>

Mechanical:<机械性能>

.Contact force: 40g±20g at 0.6mm working stroke  
 <接触弹力: 40g±20g在0.6mm的工作行程>  
 .Full stroke: 0.90mm  
 <最大行程: 0.90mm>  
 .Life test: 50,000 cycles  
 <寿命: 50000次>

Electrical:<电气性能>

.Rated current & voltage: DC 12V, 2A Max.  
 <额定电压, 电流: DC 12V, 2A>  
 .Contact resistance: 50 milliohm Max.  
 <接触阻抗: 50 milliohm Max.>  
 100% open & short test.  
 <100%导通, 短路测试>  
 专利号: ZL2014 2 0620490.0



Approve Sign

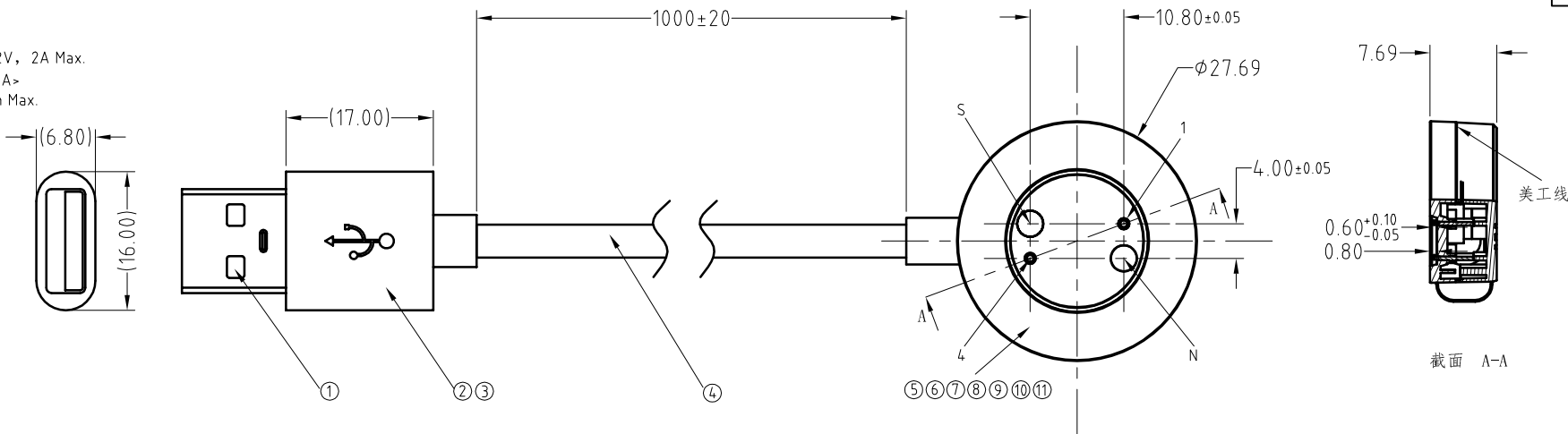

11	PCB polyester fiber board <PCB 聚酯纤维板>	B739-F1001	1
10	Pogo pin plating 0.25um Au <弹簧针 电镀金0.25um >	MP210-1122	2
9	N52 NdFeB Magnet plating Ni Cu Ni <N52 钕铁硼磁铁 表面镀镍铜镍>	B739-M2002	1
8	N52 NdFeB Magnet plating Ni Cu Ni <N52 钕铁硼磁铁 表面镀镍铜镍>	B739-M1001	1
7	Black ABS UL94 V-0 <黑色 ABS UL94 V-0>	B739-H2002	1
6	Black ABS UL94 V-0 <黑色 ABS UL94 V-0>	B739-H1001	1
5	SR Black PVC 45P <SR 黑色 PVC 45P>	B739-H3003	1
4	OD3.50 2C 24AWG Black Jacket PVC 55P 1040mm <OD3.50 2芯 24AWG 黑色 外被PVC 55P 1040mm>	X002-0203-XXXX	1
3	Black PVC 45P <黑色 PVC 45P>	B000-P0002	1
2	Lucency PE 3g <透明 PE 3克>	B000-P9001	1
1	USB/AM 0.025um Au Black salt spray test 48H <USB/AM 0.025um金 黑色 盐雾24小时>	B000-U2001	1
序号 (NO.)	规格 (Specification)	料号 (P/N)	数量 (Qty)

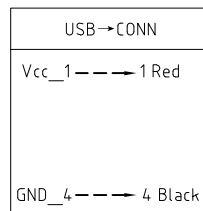

SCALE	10:1	UNIT:mm	THIS DOCUMENT IS THE SOLE PROPERTY OF CFE CORPORATION CO.,LTD., AND SHOULD NOT BE USED IN WHOLE OR IN PART WITHOUT PRIOR WRITTEN PERMISSION.	
ANGEL	±2°	A4	SHEET: 1 of 1	
0~6	±0.10			
6~30	±0.20	DRAW	PART NO.	CM-BP73911-02110H0A
30~150	±0.30	CHECK	FILE NAME	BP739XX
GENERAL TOLERANCE UNLESS OTHERWISE NOTED		APPRO	TITLE	Magnetic Cable Connector



ECN(DCN) NO.	REV	DATE	DESCRIPTION
	D0	2016.07.07	NEW