

Note:<注意>
 Mechanical:<机械性能>
 .Contact force: 40g±20g at 1.0mm working stroke.
 <接触弹力: 40g±20g在1.0mm的工作行程>
 .Life test: 20,000 cycles
 <寿命: 20000次>
 Electrical:<电气性能>
 .Rated current & voltage: DC 12V, 1A
 <额定电压, 电流: DC 12V, 1A>
 .Contact resistance: 50 milliohm Max.
 <接触阻抗: 50 milliohm Max.>

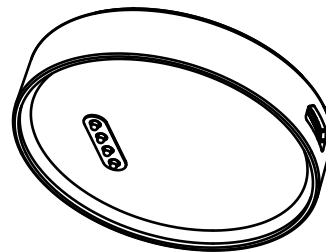

Approve Sign

A



B

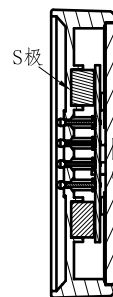
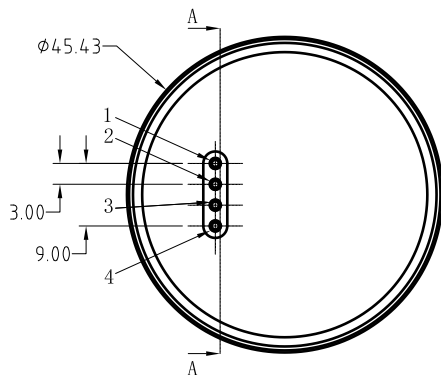
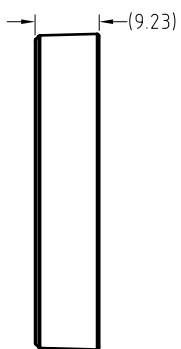

剖面 A-A

Plastic cover
 塑胶上盖

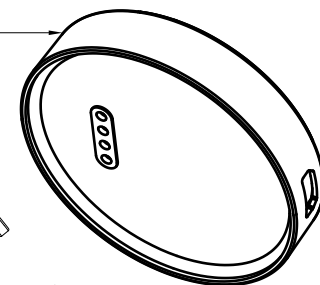

Magnet
 磁铁

tapping screw
 自攻螺丝

PCBA
 印刷电路板组件

C



Plastic bottom
 塑胶底盖

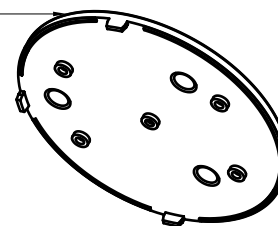

Pogo pin conn→USB
1_Vcc_1
2_GND_5
3_D+_3
4_D-_2

D

SCALE	10:1	UNIT:mm	THIS DOCUMENT IS THE SOLE PROPERTY OF CFE CORPORATION CO.,LTD., AND SHOULD NOT BE USED IN WHOLE OR IN PART WITHOUT PRIOR WRITTEN PERMISSION.	东莞市川富电子有限公司 CFE CORPORATION CO.,LTD.	
ANGEL	±1°	A4			
0~6	±0.10		SHEET: 1 of 1	PART NO.	M-BP46311-04300H0B
6~30	±0.20	DRAW		FILE NAME	BP463XX
30~150	±0.30	CHECK		TITLE	Pogo pin Connector
GENERAL TOLERANCE UNLESS OTHERWISE NOTED			APPRO		

_____	A0	2015.11.05	NEW
ECN(DCN) NO.	REV	DATE	DESCRIPTION