

Note: (注意)

Mechanical: (机械性能)

Contact force: 20g±10g at 0.4mm working stroke

(接触弹力: 20g±10g在0.4mm的工作行程)

Life test: 20,000 cycles

(寿命: 20000次)

Electrical: (电气性能)

Rated current & voltage: DC 12V; 1A

(额定电压, 电流: DC 12V, 1A)

Contact resistance: 50 milliohm Max.

(接触阻抗: 50 milliohm Max.)

100% open & short test.

(100%导通, 短路测试)

To ensure the best usage, please operate it based on the working height.

(为保最佳应用, 请基于工作高度使用)

Based on the engineering drawings, shall not exceed the maximum allowed compression.

(基于工程图纸, 不要超出最大允许压缩行程)

A

B

C

D

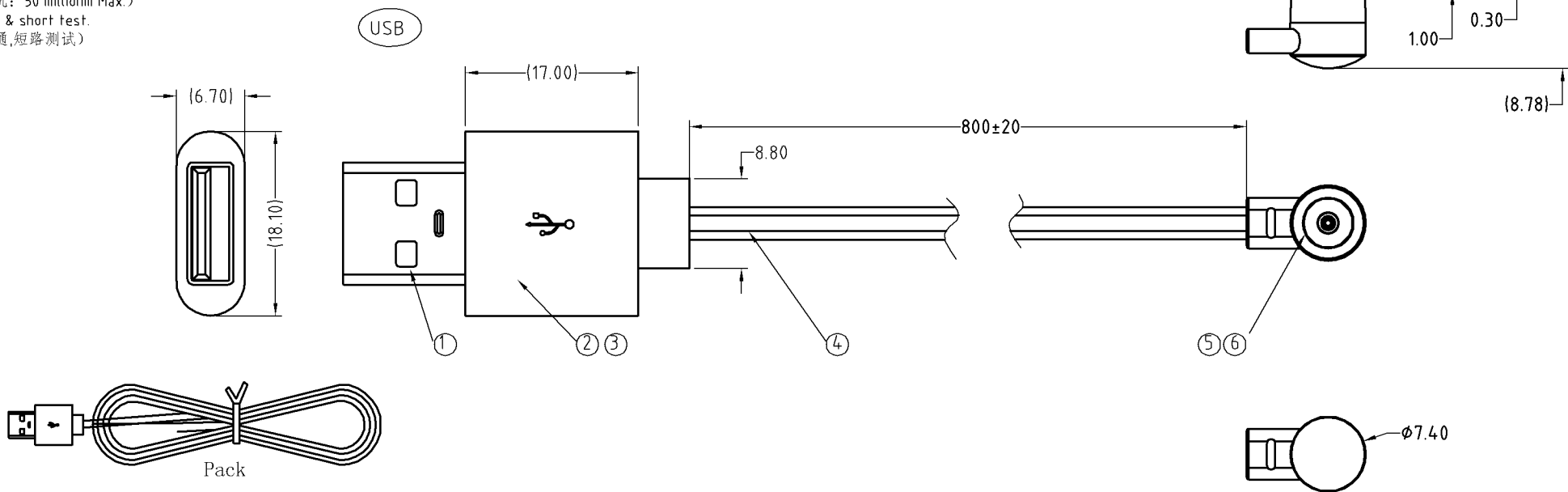

序号 (NO.)	规格 (Specification)	料号 (P/N)	数量 (Qty)
6	179 Pogo Pin Magent Connector 179 磁铁接头	M-BP50291-01000H0A	1
5	White PVC 45P <白色 PVC 45P>	B000-P0001	2g
4	N0 UL 2C 8×0.08 1.3×3.2 White PVC 840mm (N0 UL 2C 8×0.08 1.3×3.2 白色PVC 840mm)	X102-0101-XXXX	1
3	White PVC 45P <白色 PVC 45P>	B000-P0001	3g
2	Lucency PE <透明 PE>	B000-P9001	2g
1	USB/AM 0.025um Au salt spray test 48H <USB/AM 0.025um 金 盐雾 48小时>	B000-U1001	1

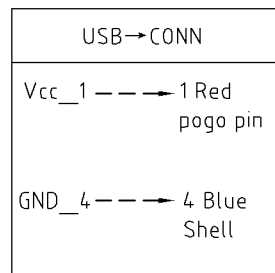

PIN OUTS

SCALE	10:1	UNIT:mm	THIS DOCUMENT IS THE SOLE PROPERTY OF CFE CORPORATION CO.,LTD., AND SHOULD NOT BE USED IN WHOLE OR IN PART WITHOUT PRIOR WRITTEN PERMISSION.		
ANGEL	±1°	A4	SHEET: 1 of 1		
0-6	±0.10				
6-30	±0.15	DRAW			
30-150	±0.20	CHECK	PART NO.	CM-BP17911-01000H0F	
GENERAL TOLERANCE UNLESS OTHERWISE NOTED			APPRO	FILE NAME	BP179XX
			TITLE	Pogo pin connector	



ECN(DCN) NO.	REV	DATE	DESCRIPTION
	D0	2016.08.25	NEW