

Note:<注意>

Mechanical:<机械性能>

- .Contact force: 70g±20g at 1.0mm working stroke
- <接触弹力: 70g±20g在1.0mm的工作行程>
- .Full stroke: 1.40mm
- <最大行程: 1.40mm>
- .Life test: 50,000 cycles
- <寿命: 50000次>

Electrical:<电气性能>

- .Rated current & voltage: DC 12V, 2A Max.
- <额定电压, 电流: DC 12V, 2A>
- .Contact resistance: 50 milliohm Max.
- <接触阻抗: 50 milliohm Max.>
- 100% open & short test.
- <100%导通,短路测试>



Approve Sign

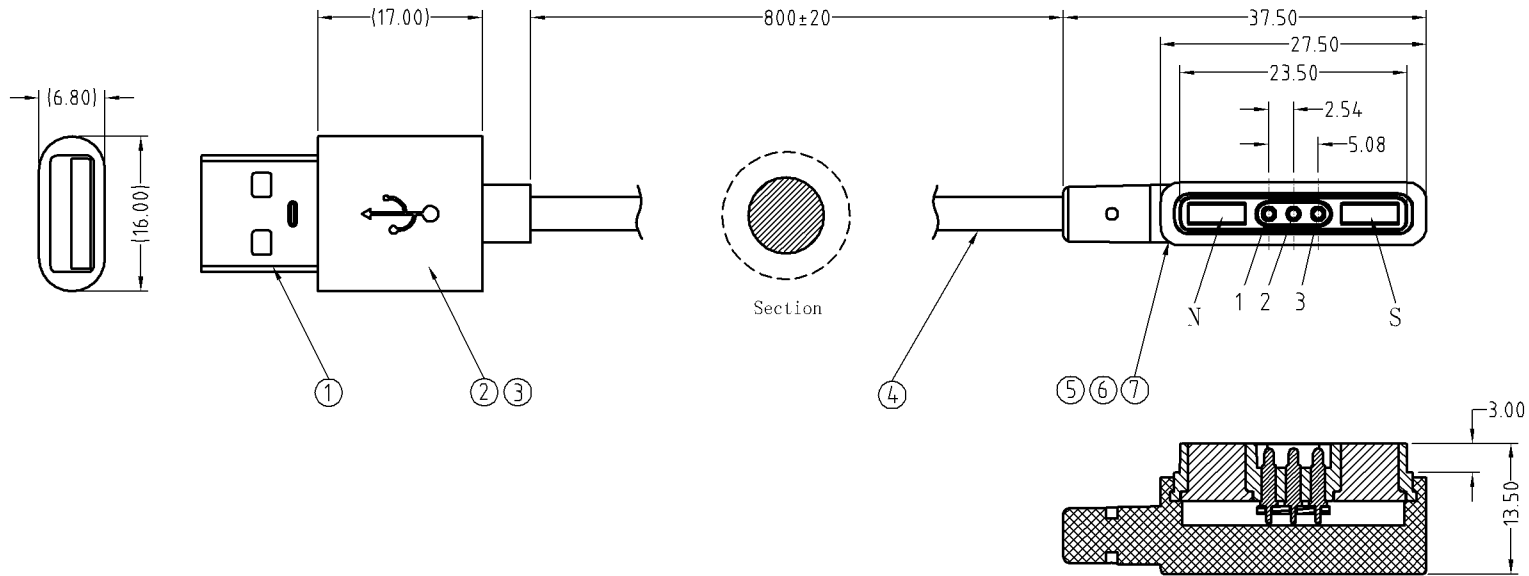

7	Magnet Connector <磁吸接头>	M-BP70102-03254A0B	1
6	Lucency PE 3g <透明 PE 3克>	B000-P9001	1
5	Black PVC UL94 V-0 4g <黑色 PVC UL94 V-0 4克>	B000-P0002	1
4	OD3.5 2C×22AWG Black Jacket PVC 5SP 840mm <OD3.5 2芯×22AWG 黑色 外被 PVC 5SP 840mm>	xxxx	1
3	Black PVC UL94 V-0 4g <黑色 PVC UL94 V-0 4克>	B000-P0002	1
2	Lucency PE 3g <透明 PE 3克>	B000-P9001	1
1	USB/AM 0.025um Au Black salt spray test 48H <USB/AM 0.025um金 黑色盐雾24小时>	B000-U2001	1
序号 (NO.)	规格 (Specification)	料号 (P/N)	数量 (Qty)

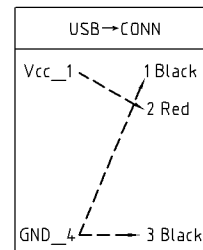

SCALE	10:1	UNIT:mm	THIS DOCUMENT IS THE SOLE PROPERTY OF CFE CORPORATION CO.,LTD., AND SHOULD NOT BE USED IN WHOLE OR IN PART WITHOUT PRIOR WRITTEN PERMISSION.	
ANGEL	±2°	A4	SHEET: 1 of 1	
0~6	±0.10		PART NO.	CM-BP70102-03254A0B
6~30	±0.20	DRAW	FILE NAME	BP701XX
30~150	±0.30	CHECK	TITLE	Magnetic Cable Connector
GENERAL TOLERANCE UNLESS OTHERWISE NOTED		APPRO		

CFE 东莞市川富电子有限公司
CFE CORPORATION CO.,LTD.

ECN(DCN) NO.	REV	DATE	DESCRIPTION
	D0	2016.06.24	NEW