

Note:<注意>

Mechanical:<机械性能>

.Contact force: 80g±20g at 1.10mm working stroke

<接触弹力: 80g±20g在1.10mm的工作行程>

.Full stroke: 1.60mm

<最大行程: 1.60mm>

.Life test: 100,000 cycles

<寿命: 100000次>

Electrical:<电气性能>

.Rated current & voltage: DC 12V, 3A .

<额定电压, 电流: DC 12V, 3A>

.Contact resistance: 50 milliohm Max.

<接触阻抗: 50 milliohm Max.>

100% open & short test.

<100%导通,短路测试>



Approve Sign

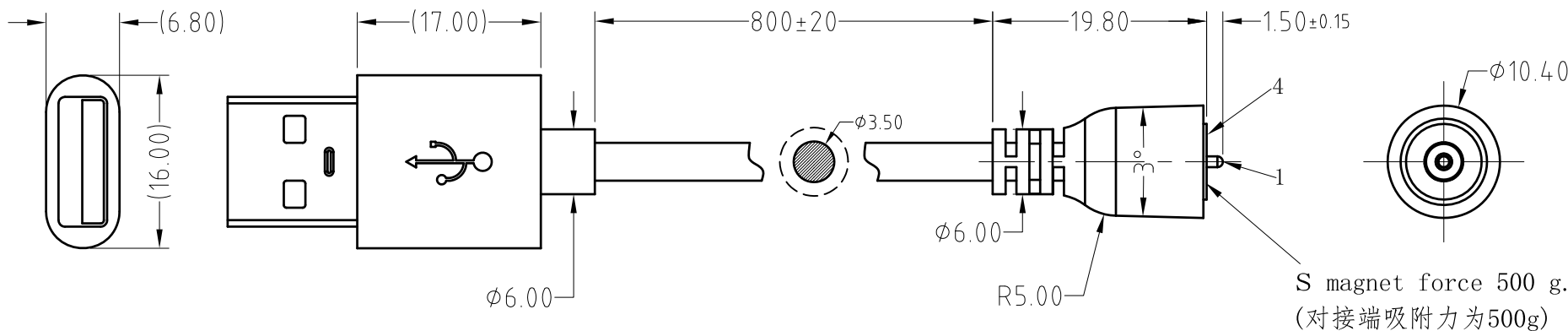

7	Magnetic Connector <磁吸接头>	M-BP60611-01000H0A	1
6	Black PVC 45P 4g <成型外被 黑色 PVC 45P 4g>	B000-P0002	1
5	Lucency PE 3g <透明 PE 3g >	B000-P9001	1
4	OD3.5 2C 22AWG UL2464 Black Jacket PVC 55P 840mm <OD3.5 2芯 22AWG UL2464 黑色 外被PVC 55P 840 mm>	X002-0208-XXXX	1
3	Black PVC 45P 4g <成型外被 黑色 PVC 45P 4g>	B000-P0002	1
2	Lucency PE 3g <透明 PE 3g >	B000-P9001	1
1	USB/AM 0.025um Au black salt spray test 48H <USB/AM 0.025um金 黑色 盐雾48小时>	B000-U2001	1
序号 (NO.)	规格 (Specification)	料号 (P/N)	数量 (Qty)

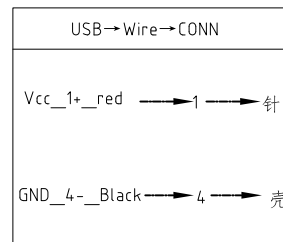

SCALE	10:1	UNIT:mm	THIS DOCUMENT IS THE SOLE PROPERTY OF CFE CORPORATION CO.,LTD., AND SHOULD NOT BE USED IN WHOLE OR IN PART WITHOUT PRIOR WRITTEN PERMISSION.	
ANGEL	±2°	A4	SHEET: 1 of 1	
0~6	±0.10		PART NO. CMA-012322-01A1A0	
6~30	±0.20	DRAW	FILE NAME CXA-0123	
30~150	±0.30	CHECK	TITLE Magnetic cable/磁吸充电线	
GENERAL TOLERANCE UNLESS OTHERWISE NOTED		APPRO		



ECN(DCN) NO.	REV	DATE	DESCRIPTION
	A0	2017.11.27	NEW