

Note:<注意>

Mechanical:<机械性能>

.Contact force: 70g±20g at 1.0mm working stroke

<接触弹力: 70g±20g在1.0mm的工作行程>

.Full stroke: 1.4mm

<最大行程: 1.4mm>

.Life test: 50,000 cycles

<寿命: 50000次>

Electrical:<电气性能>

.Rated current & voltage: DC 5V, 2A

<额定电压, 电流: DC 5V, 2A>

.Contact resistance: 50 milliohm Max.

<接触阻抗: 50 milliohm Max.>

100% open & short test.

<100%导通,短路测试>

专利号: ZL2014 2 0620498.8



Approve Sign

USB

CONN

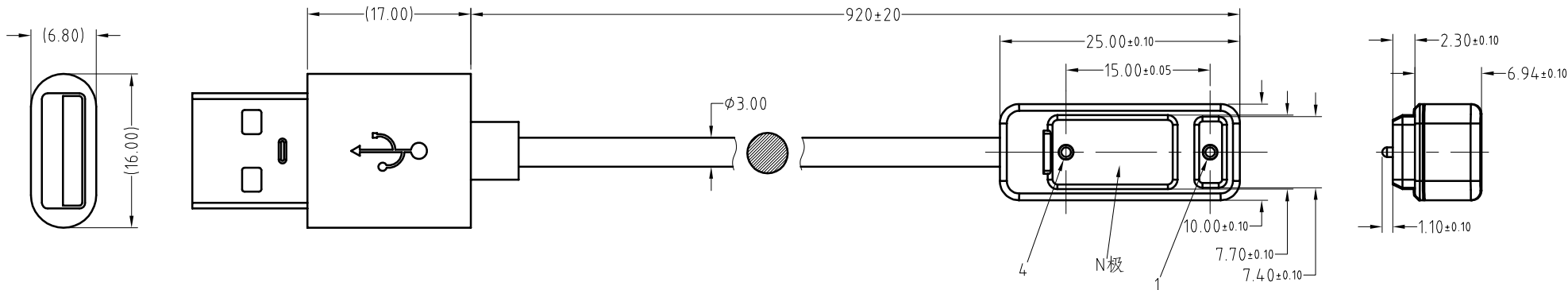

USB→CONN	
Vcc_1	→ 1 Red
GND_4	→ 4 Black

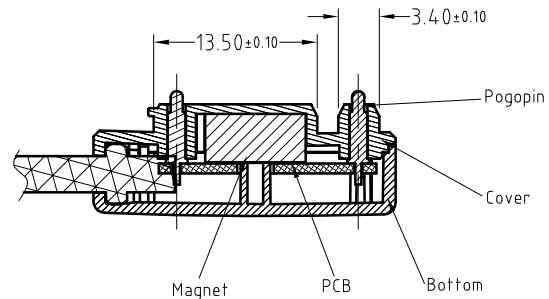

SCALE	10:1	UNIT:mm	THIS DOCUMENT IS THE SOLE PROPERTY OF CFE CORPORATION CO.,LTD., AND SHOULD NOT BE USED IN WHOLE OR IN PART WITHOUT PRIOR WRITTEN PERMISSION.		东莞市川富电子有限公司 CFE CORPORATION CO.,LTD.		
ANGEL	±2°	A4	SHEET: 1 of 1		PART NO.	CM-BP73211-02150H0A	
	0~6	±0.10		FILE NAME	BP732XX	TITLE	Magnetic Cable Connector
	6~30	±0.20	DRAW				
	30~150	±0.30	CHECK				
GENERAL TOLERANCE UNLESS OTHERWISE NOTED			APPRO				

ECN(DCN) NO.	REV	DATE	DESCRIPTION
	D0	2015.08.20	NEW